



# VALVE TECHNOLOGY

 868-648-0827/9

 [www.ialengineering.com](http://www.ialengineering.com)

 [ial@ial-int.com](mailto:ial@ial-int.com)

# OEM LICENCES

Baker Hughes™

Masoneilan

Baker Hughes™

Consolidated

 **MARC**

 **GTC**

**BECKER**  
PRECISION EQUIPMENT  
Baker Hughes 

  
mooney  
CONTROLS  
Baker Hughes 

**NW** **NEWAY**

**OMB**®  
VALVES Inc.



# VALVES

We are a Baker Hughes Original Equipment Manufacturer (OEM) provider for Masoneilan and Consolidated Valves. This includes Equipment Valves such as Control and Relief Valves. We also supply Valves for all other Applications.

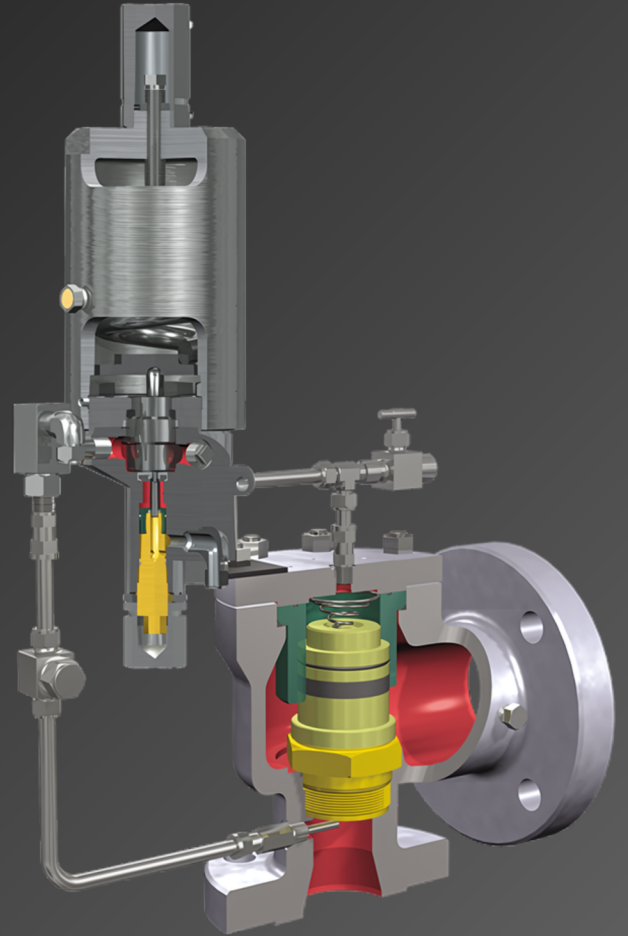
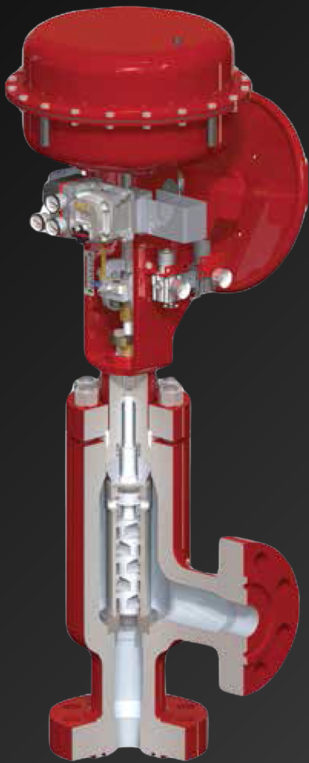

- ✓ CONTROL
- ✓ RELIEF
- ✓ BUTTERFLY
- ✓ BALL

- ✓ GATE
- ✓ GLOBE
- ✓ CHECK
- ✓ ON-OFF/SHUTDOWN



# MASONEILAN CONTROL VALVES



- ROTARY CONTROL VALVES
- GLOBE CONTROL VALVES
- SEVERE SERVICE VALVES
- ISOLATION VALVES
- DIGITAL VALVE POSITIONERS
- SOFTWARE TOOLS
- PNEUMATIC VALVE POSITIONER
- INSTRUMENTATION
- LEVEL TRANSMITTER/CONTROLLERS
- ACTUATORS
- REGULATORS



**Masoneilan**

a Baker Hughes business



# CONSOLIDATED RELIEF VALVES



- SAFETY VALVES
- SAFETY RELIEF VALVES
- PILOT OPERATED SAFETY VALVES



**Consolidated**

a Baker Hughes business



# VALVE REPAIR SERVICES



# VALVKEEP ASSET MANAGEMENT

Maximize the life span of your Valves by using our VALVKEEP Asset Management Software service. ValvKeep is a Computerized Maintenance tool that is an intuitive, easy-to-use software program that records the life events of your valves, providing status reports on valve health, future maintenance planning, and other resource-maximizing functions.

- ValvKeep software can handle any valve in your plant
- Simplifies maintenance and the data management
- Aids in parts management and spare parts
- Clients Access via web portal, view data on your Valves in real-time



# ELECTRONIC VALVE TESTING

EVT Service allows us to conduct testing in live operating conditions. EVT PRO's true in-place valve testing enables us to meet local safety requirements for periodic testing and documentation without shutting down processes or dismantling or removing valves from service. EVT PRO has state-of-the-art electronics and proprietary software, including an interface to ValvKeep\* valve maintenance and management software.



# PRESSURE TESTING SERVICES

We can perform Hydrogen, Air and Nitrogen testing with pressures up to 22,500 psi with our State of the Art High Pressure Test Bay and Underground Test Bay. Underwater Testing can be performed as well if required, and viewed via CCTV Observation.

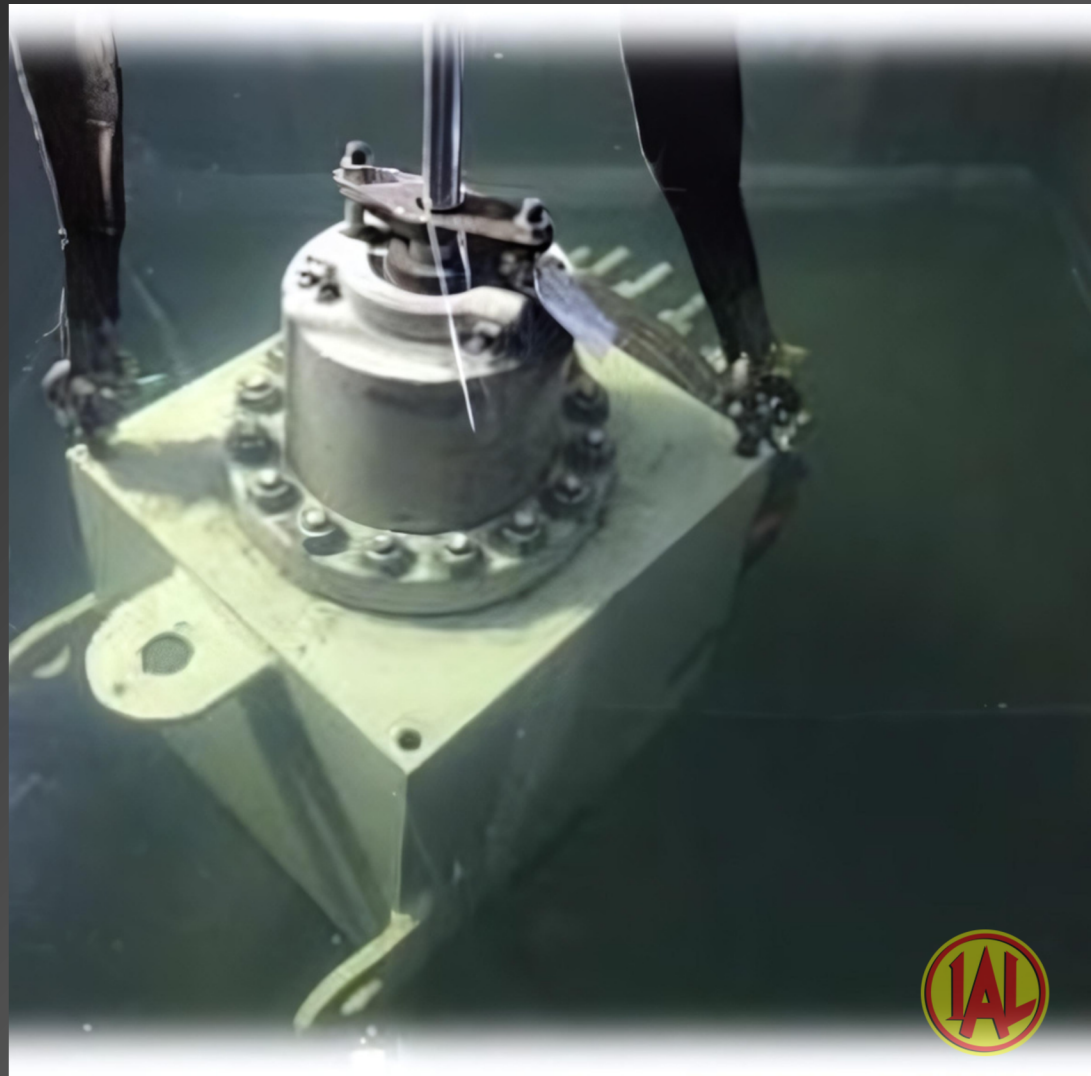

# FASTER VALVE DELIVERY WITH VALVFAST

Baker Hughes ValvFAST program enables us to respond rapidly to your needs. We are a Certified ValvFAST channel associate, able to ensure the Masoneilan and Consolidated valves you need will be on the shelf and waiting—so you can prepare for the unexpected before it happens. Get the valve you need in as little as 24 hours instead of weeks. Improved uptime and reduced downtime add up to bottom-line savings for your business.

- As a ValvFAST channel associate we can quickly configure a custom valve on site
- Both Masoneilan control valves and Consolidated pressure relief valves are available in the ValvFAST program
- You get the valves you need, when you need them—fast!



Baker Hughes 



- Shorter Lead Times
- Lower Carrying Costs
- Reduced Downtime

**Optimize Service** with ValvFAST today



# MASONEILAN AUTHORIZED REPAIR CENTER

We are also Masoneilan Authorized Repair Center (MARC) that offers factory-certified support, including OEM components, onsite service, hands-on training, and post-installation analysis to support your Control Valves Maintenance Repair Operations (MRO) needs and maximize performance efficiencies.



## Our Services Include:

- Commissioning
- Mechanical Inspection
- Valve Repair
- Shutdown Planning
- Onsite Repairs
- Troubleshooting
- OEM Parts
- Retrofits
- Re-instrumentation
- Asset Management
- Predictive Maintenance
- Site Surveys
- Remote and Real Time Valve Testing



# CONSOLIDATED AUTHORIZED GREEN TAG CENTER

Our Green Tag Center (GTC) is staffed with highly qualified technicians who have been specifically trained and certified to deliver exceptional product support and technical expertise.



## Our Services Include:

- Commissioning
- Mechanical Inspection
- Valve Repair
- Shutdown Planning
- Onsite Repairs
- Troubleshooting
- OEM Parts
- Retrofits
- Compliance Management
- Asset Management
- Predictive Maintenance
- Site Surveys



# VALVE SHOP

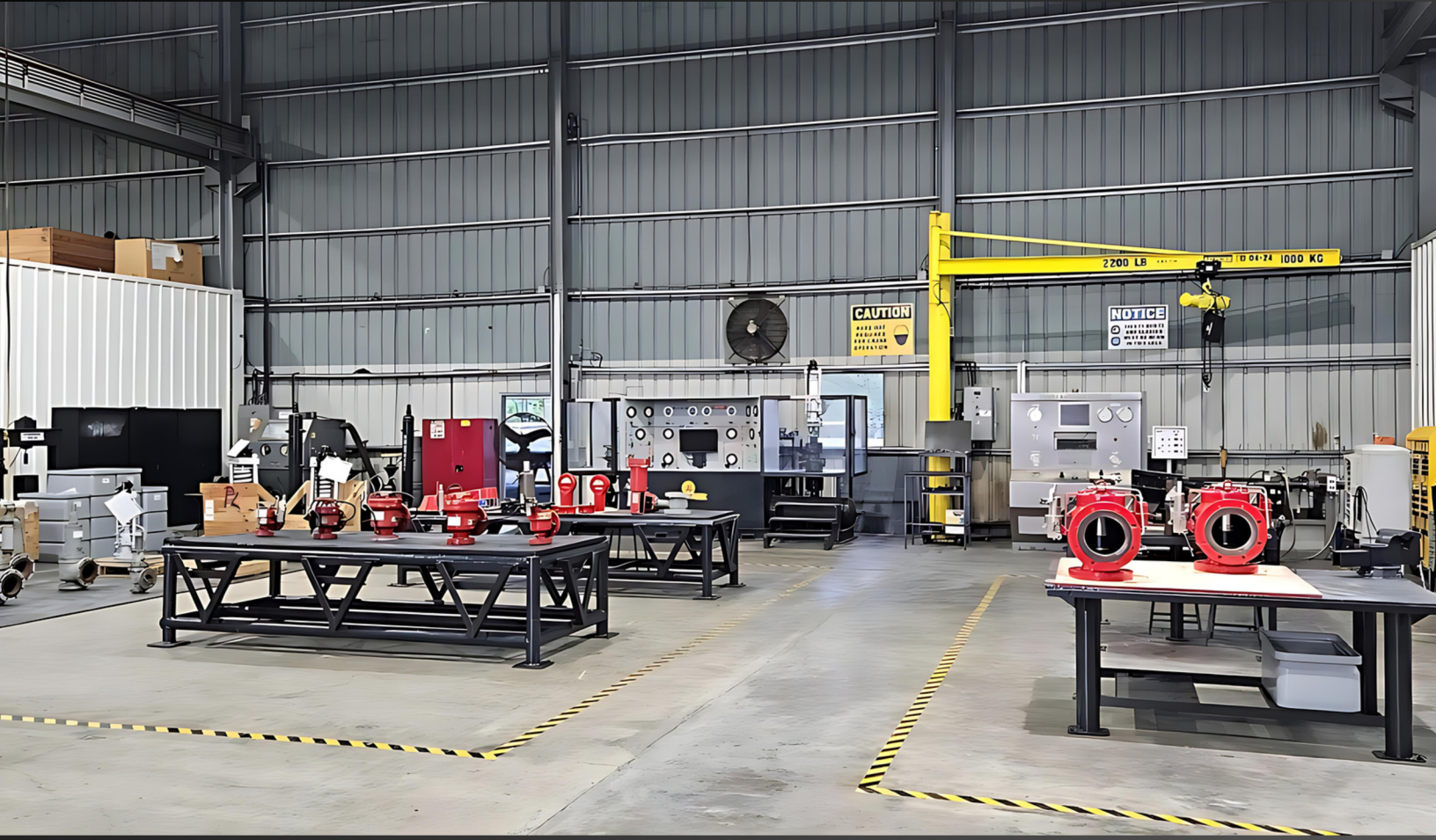

# VALVE TEAM



# LET'S DISCUSS SOLUTIONS

Manager- Equipment Services

Tariq Alsuran

Phone: (868) 382-2483

Email: tariq@ial-int.com

Applications Engineer-

Valve Technology

Vishal Ragbir

Phone: (868) 382-2042

Email: vishal@ial-int.com

Contact Details

Trinidad: (868) 648-0827/9

Guyana: (592) 683-3351

Email: ial@ial-int.com

Visit us [@www.ialengineering.com](http://www.ialengineering.com)



SCAN  
me! 



## INTEGRATED SOLUTIONS

- ✓ **Valve Technology**
- ✓ Wellhead Solutions
- ✓ Tubular Services
- ✓ Equipment Services
- ✓ Corrosion Solutions
- ✓ Fabric Maintenance
- ✓ Marine Services

